

MORPHOLOGY AND TAXONOMY OF THE GENUS *TRIANGULOPSIS* DÖRING 1961

K. P. JAIN

Birbal Sahni Institute of Palaeobotany, Lucknow

ABSTRACT

The communication presents a new morphological and taxonomical treatment of the pollen genus *Triangulopsis* Döring (1961). The new interpretation reveals the presence of a perinosaccus which is an outer loose fitting covering resembling both a saccus and a perispore, enveloping an alete or porate pollen body, attached or free with the body. A suggestion is also put forth to maintain *Triangulopsis* and *Applanopsis* as two distinct genera which should be treated separately from *Tsugaepollenites* (Pot.) Pot. & Ven.

INTRODUCTION

POTONIÉ (1931, p. 555) described some pollen grains as *Sporonites igniculus* from the Tertiary beds of Germany. Later Potonié and Venitz (1934, p. 17) compared the *Sporonites igniculus* pollen grains with the pollen grains of the living *Tsuga* spp. They suggested a very close resemblance with *Tsuga* pollen grains and therefore, instituted another genus *Tsugaepollenites* designating *Tsugaepollenites* (*Sporonites*) *igniculus* (Pot.) Pot. & Ven. as its genotype. Later Pflug (in THOMS. & PFLUG, 1953, p. 66) proposed the name *Zonalapollenites* for pollen grains described earlier by Pot. (*l.c.*) as *Sporonites igniculus*, without assigning any genotype or illustrations. It is therefore rejected on grounds of priority and invalidity of the name against *Tsugaepollenites*.

A perusal of the Mesozoic palynological literature indicates that a few western Australian miospores described by Balme (1957) as *Zonalapollenites* spp. are in a controversial morphological and taxonomical state and have been assigned five different generic names, viz., *Triangulopsis* Döring (1961), *Applanopsis* Döring (GOUBIN *et al.*, 1965), *Callialasporites* Dev (1961), *Pflugipollenites* Pocock (1962) and *Tsugaepollenites* (Pot.) Pot. & Ven. (DETMANN., 1963).

Goubin *et al.* (*l.c.*, p. 227) are of the opinion that *Applanopsis* Döring (1961) embraces all the above mentioned genera

excepting *Tsugaepollenites* and have rejected them on grounds of priority.

SYSTEMATIC DESCRIPTION

Anteturma — *Pollenites* Pot., 1931
Turma — *Perinosaccati turma* nov.

Diagnosis — Alete or porate pollen grains enveloped by a perinosaccus.

Genus *Triangulopsis* Döring emend.

(For illustrations see Sah & Jain, 1965, pl. 3, figs. 81-84; pl. 4, figs. 88-91 and pl. 7, fig. 153)

1961 — *Triangulopsis* Döring, p. 113

Emended Diagnosis — Pollen grains alete, body broadly triangular to subtriangular, perinosaccus well developed, enveloping body, attached on one side of it along tri-radiate streak, almost free on other side (TEXT-FIG. 1A). Body exine smooth or scabrate. Perinosaccus surface ornamented with minute or coarse granules or even bacula. Marginal crassitudo along perinosaccus margin prominent. Radial folds, extending from body region towards outer extension of perinosaccus, distinct and frequent or even some times absent when fully expanded.

Description — Pollen grains 50-155 μ in size; body biconvex. Perinosaccus attached with body along the triradiate streak covering contact area which is variable (TEXT-FIGS. 1 B-C).

Genotype — *Triangulopsis trilobatus* (Balme) Döring.

Remarks — Döring (1961, p. 114) established the genus *Triangulopsis* with two species, viz., *T. discoidalis* and *T. trilobatus* (Balme), and made former species as the genotype whereas the latter has priority and should therefore be taken as its genotype.

Goubin *et al.* (1965, p. 227) considered *Triangulopsis* as a synonym of *Applanopsis*, elaborating the generic circumscription of the latter. But the miospores included under the genus *Triangulopsis* always possess

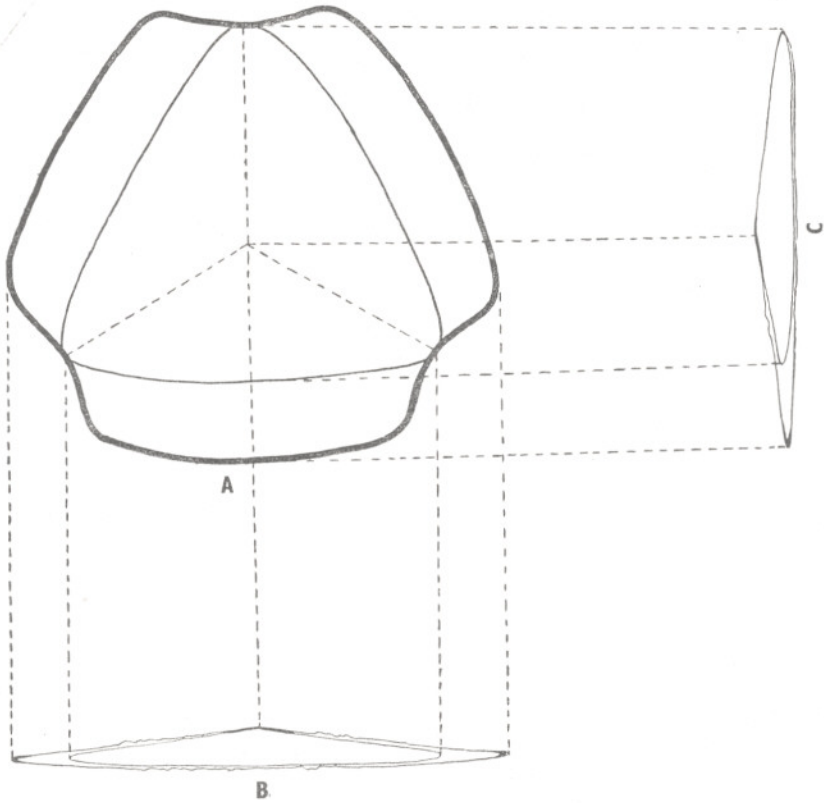

TEXT-FIG. 1—Diagrammatic representation of *Triangulopsis trilobatus* (Balme) Döring. 1A, same in polar view showing the three lobed bladder with crassitubo and the tetrahedral crest (in dotted line). 1B, same in cross-section showing the nature of the perinosaccus. 1c, same showing the attachment of perinosaccus with the body along the tetrahedral crest.

a triangular body and thick perinosaccus with marginal crassitudo and extra ornamentation whereas the miospores of *Applanopsis* clearly show a circular rounded body with thin perinosaccus resembling that of *Perinopollenites* Couper. The author, therefore, maintains these two genera as distinct from each other.

Morphological Considerations—Most of the previous workers viz., Balme (1957), De Jersey (1960), Dev (1961), Döring (1961), Dettmann (1962), Singh *et al.* (1964), Goubin *et al.* (1965) and Sah and Jain (1965) considered these miospores (*in* BALME, *l.c.*; PL. 8, FIGS. 88-92; PL. 9, FIGS. 93-94) as monosaccate with equatorially attached saccus.

Pocock (1962, p. 72) for the first time suggested the term *perispore* for the so-called bladder, bladders, or monosaccus, used by Balme (*l.c.*) etc. But in the diag-

nosis he also mentions both the terms perispore or bladder for the outer covering, though he emphasized more on its being a perispore. While describing the genus *Pflugipollenites*, he postulated the following diagnosis, "Trilete to alete grains possessing a thin walled hyaline bladder or perispore which either envelops the entire central body or in some species the distal hemisphere; central body circular to subtriangular, laevigate to granulose, perispore frequently characteristically radially folded".

The present reinterpretation of the genus *Triangulopsis* Döring is based on further studies of the Rajmahal material on which Sah and Jain (1965) published a paper. Help has also been taken from the observations of Pocock (1962, p. 72) and the cross-sections of the similar miospores illustrated by Dettmann (1963, PL. 24, FIGS. 9-10).

The study reveals that the miospores of the type species *Triangulopsis trilobatus* possesses a triangular to subtriangular body, enveloped by a loose fitting outer covering with extra ornamentations on the surface; radial folds frequent, outer covering attached along the triradiate streak which some times form a triradiate fold appearing like a false Y-mark.

From the above statement it is quite evident that the loose fitting outer covering and its extra ornamentation suggest a perine or perispore feature whereas the presence of prominent radial folds and its attachment with the body are suggestive of a saccus nature and therefore to use the term subsaccus for the outer covering alone would not serve the purpose.

The bladders or sacci in the gymnosperms are produced as expansions of the sexinous layer (UENO, 1960; p. 113) and therefore, possess columella inside, which are unconnected with the nexine layer (POTONIÉ & KREMP, 1955; p. 19). The radial folds developed in these miospores are sometimes confused for the columella like structures but this does not hold true.

The loose fitting outer covering with extra granular ornamentation on the surface of the *Triangulopsis* type of pollen grains indicate a close similarity with the bilateral spores of Aspidiaceae, in which the presence of perispore is a rule, though it may sometimes be reduced or lost (NAYER & DEVI, 1964). According to Kremp (1965, p. 114) one cannot be sure, apparently of the correct application of such terms as ectexine and perine without reference to the ontogeny of the spore, which in case of fossil spores would not be known. Erdtman (1947), Hanning (1911) and Skottsberg (1942) as cited in Kremp (*l.c.*) are also of the same opinion.

In view of the doubtful nature of saccus and the nonapplicability of the direct term perine or perispore in the fossil state, it is suggested here to use the term *perino-cavate* as proposed by Harris (1955, p. 25) for the fossil pteridophytic spores and the term *perinosaccate* for the gymnospermous pollen grains where the distinction between a perispore and a saccus is not marked or shows mixed features of both the saccus and the perine. The latter suggestion is in support of Faegri and Iversen (1950) as cited in Kremp (1965, p. 115) who pointed out that "... for pollen grains in which the

ectexine is loosened from the endexine, and might be similarly used of spores, though the terms saccate or vesiculate where appropriate, may be taken to imply this condition. The prefix perino — might be used if it is necessary to indicate that the layer which is cavate is regarded as a perispore". It has also been supported by Thomson and Pflug (1953, p. 17) and Couper (1958, p. 103).

Taxonomical Consideration — The genus *Triangulopsis* has been placed under the Anteturma Pollenites even though it shows some affinities with the aspidiaceous spores discussed elsewhere but the spores of Aspidiaceae are monolete, while those of *Triangulopsis* are alete. According to the nomenclature of *Sporae dispersae* adopted by Potonié and Kremp (1954, 1955, 1956) and subsequently reorganized by Potonié (1956, 1958, 1960), the Anteturma Pollenites embraces the miospores which possess pores, colpi, sacci or are simple alete forms (after Hart, 1965, p. 5). The subdivision of the Anteturma has been made according to the presence or absence of sacci and the type of aperture. The *Triangulopsis* pollen grains having a perinosaccus do not fit in any of the so far existing Turma and therefore, a new Turma *Perinosaccati* is proposed to include all alete or porate perinosaccate pollen grains.

Discussion — Dettmann (1963, pp. 99-102) published an extensive account of the Upper Mesozoic miofloral assemblage from S.E. Australia and discussed at length the morphology and the taxonomy of the genus *Tsugaepollenites*. She included several genera in the list of synonymy, but only *Triangulopsis* is treated here for the purpose of discussion.

The morphological concept of the genus *Tsugaepollenites* put forth by Potonié and Venitz (1934, p. 17) and Potonié (1958, p. 48) clearly indicates that the pollen grains are polygonal to circular in outline with narrow equatorial flange and rugulate to reticulate central body exine with small muri or warts. Manum (1962, pp. 45-46) states that the corrugated protrusions forming the conspicuous sculpturing, are hollow and the grains are hetropolar. He described the distal side as usually depressed. Macko (1957, pp. 33-35) described some *Tsuga* pollen from the Lower Miocene of Kloonica near Gliwice (Upper Silesia) as *Tsuga canadensis* Carr., *T. diversifolia*

(Maxim.) Mast, *T. caroliniana* Engelm. and *T. pattoniana* Engelm. He described the pollen grains of *T. canadensis* like a deep bowl surface covered with vermicules where as those of *T. pattoniana* possess air bladders covered with reticulum. The species *Tsuga pattoniana* (Hesperopeuce) has been treated as a primitive one by Kirchheimer (1934), Wodehouse (1935) and Ueno (1957) suggesting that the present day pollen grains of *Tsuga* spp. are derived from a winged ancestral form through the suppression of bladder. *Tsuga sieboldii* and *T. diversifolia* are considered to be advanced members because they possess a rudimentary bladder or a large marginal ridge.

None of the following features of *Tsuga* or *Tsugaepollenites*, viz., 1) bowl likedepression in the centre of the body, 2) marginal ridge along the body, 3) reticulum on the bladder surface of the normal *Tsuga* pollen, 4) presence of narbe and 5) disaccate normal bladder (*Tsuga pattoniana*) as a primitive feature, are present in the *Triangulopsis* type of pollen grains; though the occurrence of triradite streak appears to be in common to both. The triradial streak is also seen in *Podocarpus dactyloides*. Gamero (1965, PL. 2, FIG. 3) illustrated such pollen grains *in situ*, in tetrad and therefore, an occurrence of trilete scar can be expected.

The distribution of these genera also has some bearing for their separation. From the published records it is found that

Tsugaepollenites and fossil pollen grains of *Tsuga* are known to occur only from the Tertiary rocks of Northern Hemisphere ranging from Palaeocene to Pliocene. Only two Mesozoic forms viz., *Tsugaepollenites mesozoicus* Couper (1958, p. 155) and *Tsuga* type of pollen described by Reissinger (1950, pp. 111-112) are known till now. But these are also doubtful as pointed out by Nilsson (1958, p. 73) who transferred *T. mesozoicus* to a new genus *Cerebropollenites*, assigning its affinities with the coniferae. These discussions also caught the attention of Florin (1958, p. 382) who remarked that no forms which could be expected to have produced such pollen grains are known as yet from the Jurassic. It is also important to note that the composition of southern fossil conifer floras shows a total absence in them of any trace of Pinaceae (FLORIN, 1951, p. 83). Whereas, the plants producing pollen grains of *Triangulopsis* type were at their optimum from early Jurassic onwards and were world wide in distribution.

ACKNOWLEDGEMENTS

The author is deeply indebted to Dr. D. C. Bharadwaj for kindly going through the manuscript and for his helpful criticisms. Author is also thankful to Dr. S. C. D. Sah for his keen interest taken during the progress of the manuscript.

REFERENCES

- BALME, B. E. (1957). Spores and pollen grains from the Mesozoic of Western Australia. *Sci. Ind. Res. Org.* **25**: 1-48.
- COUPER, R. A. (1958). British Mesozoic microspores and pollen grains. A systematic and stratigraphic study. *Palaeontographica. B.* **103** (1-3): 75-179.
- DE JERSEY, N. J. (1960). Jurassic spores and pollen grains from the Rosewood Coalfield. *Geol. Surv. Qd. Publ. No.* 294.
- Idem (1963). Jurassic spores and pollen grains from the Marburg sandstone. *Ibid.* **313**: 1-15.
- DETMANN, M. E. (1963). Upper Mesozoic microfloras from south eastern Australia. *Proc. R. Soc. Vict.* **77** (1): 1-148.
- DEV, S. (1961). The fossil flora of the Jabalpur Series—3. Spores and Pollen grains. *Palaeobotanist.* **8** (1-2): 43-56.
- DÖRING, H. (1961). Planktonartige Fossilien des Jura/Kreide Grenzbereichs der Bohrungen Werle (Mecklenburg). *Geologie.* **10** (32): 110-121.
- ERDTMAN, G. (1947). Suggestions for the classification of fossil and recent pollen grains and spores. *Svensk bot. Tidskr.* **41** (1): 104-114.
- FAEGRI, K. & IVERSEN, J. (1950). Text-book of modern pollen analysis. *Copenhagen.*
- GAMERO, J. C. (1965). Morfología del pollen de *Apterocladus lanceolatus* Archang. (Coniferae) de la formación Baqueró, provincia de Santa Cruz. *Rev. Ass. Palaeont. Argentina.* **4**: 133-136.
- GOUBIN, N., TAUGOURDEAU, J. & BALME, B. E. (1965). Considérations taxinomiques sur deux espèces de pollen du Mésozoïque. *Revue Micropaleont.* **7** (4): 225-227.
- HART, G. F. (1965). The systematics and distribution of Permian miospores. Johannesburg.
- KIRCHHEIMER, F. (1934). Über *Tsuga*—pollen aus dem Tertiär. *Planta.* **22** (2): 171-179.
- Idem (1950). Mikrofossilien aus Salzablagerungen des Tertiärs. *Palaeontographica. B.* **90**: 127-160.
- KREMP, G. O. W. (1965). Morphologic encyclopedia of Palynology. *Tucson.*
- MANUM, S. (1962). Studies in the Tertiary flora of Spitzbergen, with notes on Tertiary floras of Ellesmere Island, Greenland and Iceland. *Norsk Polarinst.* **125**: 1-127.

- MACKO, S. (1957). Lower Miocene pollen flora from the valley of Kodnica near Gliwice (Upper Silesia). *Pr. Wroc. Tow. nauk. B.* **88**: 1-312.
- NAYER, B. K. & DEVI, S. (1964). Spore morphology of Indian ferns. 1. Aspidiaceae. *Grana palynol.* **5** (1): 80-120.
- NILSSON, T. (1958). Über das vorkommen eines Mesozoischer Sapropelgesteins in Schonen. *Inst. Min. Palaeont. Quart. geol.* **53**: 5-112.
- POCOCK, S. A. J. (1962). Microfloral analysis and age determination of strata at the Jurassic — Cretaceous boundary in the Western Canada plains. *Palaeontographica.* **111** (B): 1-95.
- POTONIÉ, R. (1931). Zur Mikroskopie der Braunkohlen iv 2. *Braunkohle.* **30**: 554-556.
- Idem (1956). Synopsis der Gattungen der Sporae dispersae. I. *Beih. geol. Jb.* **23**: 1-103.
- Idem (1958). Synopsis der Gattungen der Sporae dispersae. II. *Ibid.* **31**: 1-114.
- POTONIÉ, R. (1960). Synopsis der Gattungen der Sporae dispersae. III. *Ibid.* **39**: 1-189.
- POTONIÉ, R. & KREMP, G. (1954). Due Gattungen der Palaeozoischen sporae dispersae und ihre stratigraphic. *Geol. Jb.* **69**: 111-194.
- POTONIÉ, R. & KREMP, G. (1955). Die Sporae dispersae des Ruhrkarbons, ihre Morphographie und Stratigraphie mit Ausblicken auf Arten anderer Gebiete und Zeitabschnitte. *Palaeontographica.* **98**: 1-136.
- POTONIÉ, R. & VENITZ, H. (1934). Zur Mikrobiologie des Kohlen und ihrer Verwandren I. Zur Mikrobiologie des miozänen Humodils der niederrheinischen Bucht. *Preuss. Geol. Handlt.* **4** (44): 1-54.
- RAATZ, G. V. (1937). Mikrobiologisch-stratigraphische untersuchung der Braunkohle des Muskauer Bogens. *Abb. preuss. geol.* **183**: 1-48.
- REISSINGER, A. (1950). Die "Pollenanalyse" ausgedehnt auf alle Sedimentgesteine der geologischen Vergangenheit. *Palaeontographica.* **90**: 99-126.
- SAH, S. C. D. & JAIN, K. P. (1965). Jurassic spores and pollen grains from the Rajmahal Hills, Bihar, India: with a discussion on the age of the Rajmahal intertrappean beds. *Palaeobotanist.* **13** (3): 264-290.
- SINGH, H. P., SRIVASTAVA, S. K. & ROY, S. K. (1964). Studies on the Upper Gondwana of Cutch I. Mio- and Macrospores. *Ibid.* **12** (3): 282-306.
- THOMSON, P. W. & PFLUG, H. (1953). Pollen und Sporen des mitteleuropäischen Tertiärs. *Palaeontographica.* **94**: 1-138.
- UENO, J. (1957). Relationships of genus *Tsuga* from pollen morphology. *J. Inst. Polytech. Osaka Cy. Univ.* **8** (D): 191-196.
- Idem (1960). Studies on pollen grains of Gymnospermae concluding remarks to the relationships between coniferae. *Ibid.* **11** (D): 109-136.
- WODEHOUSE, R. P. (1935). Pollen grains. *New York.*